

# Palintest®

# Soil Management Kit

## Contents List

Palintest Soil Tests – Soiltester System and Company Info	2
Schematic Diagram of the Kit	5
Soil Sampling and Extraction	6
Soil Extraction Procedures	7
Soil pH/Lime Requirement	11
Conductivity	15
Nitrate (N)	16
Phosphate (P)	17
Potassium (K)	18
Magnesium (Mg)	20
Calcium (Ca)	21
Conductivity Test Instructions	23
General Instructions	24
Nutrient level Guide	25

**To ensure maximum accuracy, this kit should only be used in conjunction with Palintest products.**

**All Palintest instruments and reagents are manufactured in, and distributed from the UK.**

## THE PALINTEST SOILTESTER SYSTEM

Soil testing plays a vital role in modern agricultural and horticultural management. Regular assessment of major nutrient levels in the soil is essential to make fertiliser recommendations and to ensure optimum growing conditions.

The Palintest system of soil testing is unique. Simple to use test equipment, and reagents in stable tablet form, mean that reliable results can be obtained by all users - with or without formal training in soil analysis.

This is why the Palintest system is used by farmers, growers and specialists throughout the world - you can rely on years of Palintest experience for your soil testing needs.

The Palintest Soiltester system offers a rapid reliable means of soil analysis. The system uses Palintest Soiltester blocks - simple to use colour comparison blocks.

The Palintest Soiltester blocks are integrated with the Palintest range of soil extraction and reagent tablets. They offer therefore a simple colorimetric method of analysis for a range of important soil tests.

Major nutrient tests are carried out by first extracting the nutrients from the soil, and then testing the extracts by simple test procedures. The tests for nitrate and phosphate use colour comparison methods in conjunction with the N/P/Mg Soiltester block. The potassium test uses a simple procedure based on the amount of turbidity (cloudiness) formed in the sample, and the calcium test is based on the Palintest tablet count method.

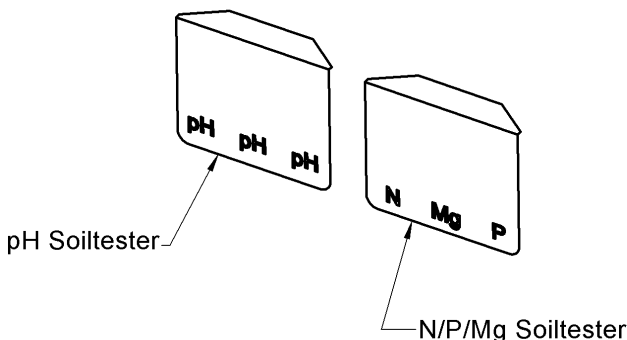

## **SOIL ANALYSIS APPLICATIONS**

Soil analysis is a complex subject. The wide variation in soil types and crops under cultivation has promoted many different methods of soil analysis. Often the results obtained must be related to the method of analysis used.

Whilst precise laboratory analysis undoubtedly has a vital role, simple methods of field testing can be immensely useful in soil management. In particular results can be obtained quickly and economically. Field tests can be conducted in order to make fertiliser recommendations, to check if further tests are needed or to determine if samples should be collected for specialist analysis.

Palintest soil tests are equally suited for use in the field and in the laboratory. Palintest soil test kits are an important part of any agricultural or horticultural management programme.

## **CORRELATION OF RESULTS**

Chemical elements are often strongly bonded or complexed within the soil structure. Soil analysis measures the nutrients or trace elements which are 'exchangeable' or 'extractable' under the conditions of the test. The amounts will depend on the nature of the extraction method and the time of contact. Thus whilst a general relationship exists between different methods of soil analysis, precise correlation can sometimes be difficult.

In developing Palintest methods regard has been paid to standard laboratory methods of soil testing (Ref - 1, 2). Correlations have been established for the pH, Lime Requirement, Nitrate (N), Phosphate (P), Potassium (K) and Magnesium (Mg) methods (Ref - 3). These tests should give similar results to United Kingdom ADAS methods for normal agricultural soils. However, in view of the wide variation in soil types it is not possible to guarantee that precisely similar results will be obtained in all cases.

Test results should always be considered in relation to the fertiliser programme applied and the conditions of cultivation. In the event of unexpected test results being obtained, such as very high or very low values, then it is recommended that samples are submitted for laboratory analysis. A guide level for each nutrient is provided on page 25.

## **FERTILISER RECOMMENDATIONS**

Fertiliser recommendations are outside the scope of these soil test instructions. It is suggested that users refer to standard fertiliser recommendations such as those published by ADAS (Ref - 4) in the United Kingdom and by government agencies in other countries.

## **REFERENCES**

- 1 The Analysis of Agricultural Materials; Agricultural Development and Advisory Service; Ministry of Agriculture, Fisheries and Food; Reference Book RB 427.
- 2 Methods of Soil Analysis; American Society of Agronomy, 1965, 5th printing 1979.
- 3 Comparison of Palintest Soil Test Methods with Standard Laboratory Procedures, Colin Marks and Valerie Argent, Palintest Ltd.
- 4 Fertiliser Recommendations; Agricultural Development and Advisory Service; Ministry of Agriculture, Fisheries and Food; Reference Book 209.

Palintest Ltd

Palintest House, Kingsway, Team Valley, Gateshead, Tyne & Wear, UK  
NE1 1 ONS

Tel: +44 (0) 191 491 0808 Fax: +44 (0) 191 482 5372

E-Mail: [palintest@palintest.com](mailto:palintest@palintest.com)

Palintest Asia/Pacific

Unit 1/53, Lorraine St, Peakhurst, NSW 2210, Australia

Tel: +61 1300 13 15 16 Fax: +61 1300 13 19 86

Palintest USA

21 Kenton Lands Road, PO Box 18395, Erlanger, Kentucky, 41018, USA

Tel: +01 (859) 341 7423 Fax: +01 (859) 341 2106

Palintest China

Room 1601, KunTai International Mansion, 12B ChaoYang District, Beijing,  
100020, PRC

Tel: +86 10 5126 1868-809 Fax: +86 10 5126 1868-809

# Schematic Diagram of the Kit

## Case :-

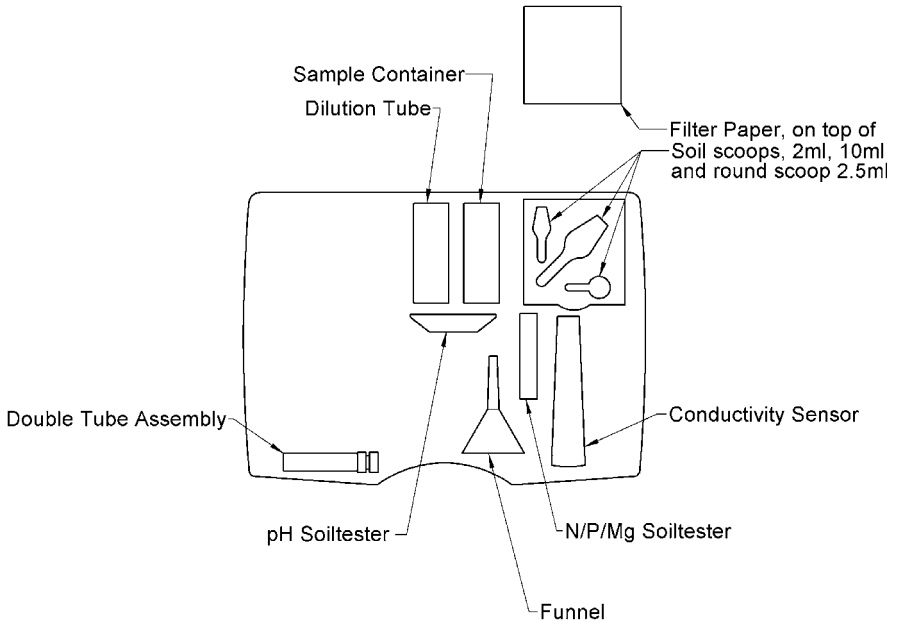

## Reagent Bag :-

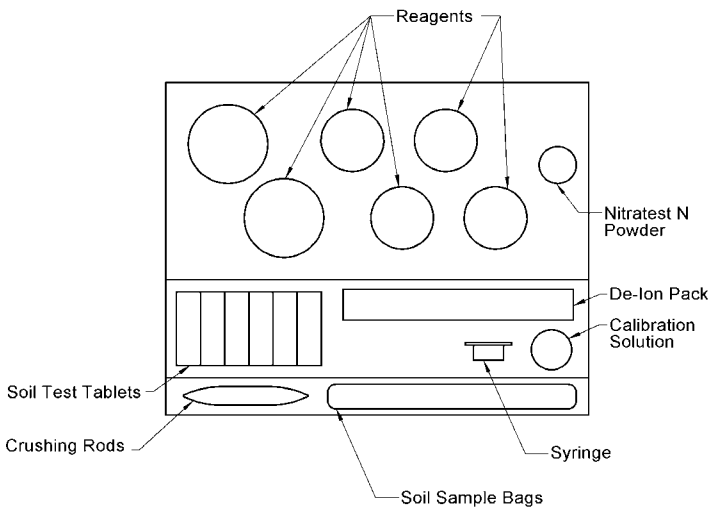

## SOIL SAMPLING

A soil sample should be collected from each plot or area to be examined. Separate samples should be collected from each area, which differs in soil type, previous cropping history or type of soil management.

Preferably, samples of soil should be taken using a soil sampling auger which enables 'cores' of soil to be taken from below the surface. Alternatively, a piece of narrow rigid tubing may be used. Between 10 and 25 individual cores should be taken from each area to make up the soil sample for analysis. It is customary when sampling large areas of agricultural land to take cores along the shape of an imaginary W covering the area being sampled. Cores should not be taken close to hedgerows, under trees or adjacent to buildings.

To provide the sample for analysis, the individual cores should be thoroughly mixed in a bucket. Stones and foreign materials should be removed by hand. The soil can be passed through a 2 mm sieve or similar if this is available. The sample can then be transferred to a polythene sample bag (PT 301).

For field analysis, the tests may be conducted directly on the moist sample. Where analysis is to be carried out at a later time, it is preferable to dry the sample by spreading it out on a tray or plastic sheet and allowing it to stand in air.

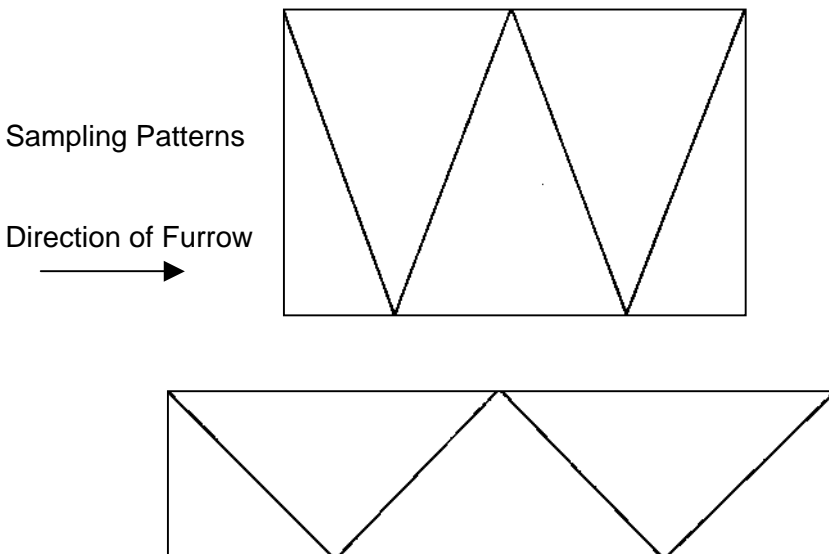

## SOIL EXTRACTION

Soil extraction is the first stage in soil testing. The soil is shaken with an extracting solution in order to extract the nutrient or trace element from the soil.

Certain groups of tests use the same extraction procedure. It is only necessary to prepare a single extract for each group of tests.

**NOTE THAT THE EXTRACTION PROCEDURES USE TWO DIFFERENT SIZES OF SOIL SAMPLE SCOOP - 2 ml AND 10 ml.**

An outline of the extraction scheme used for the various tests is shown in the following table :-

Test	Extract	Extract Chemical	Extraction Tablets	Water	Soil
Soil pH Lime Requirement	N/A		No extraction required. Tests are carried out directly on the soil sample.		
Nitrate (N)	Extract N	1M Ammonium Chloride	One level blue extraction scoop Extraction N Powder plus one universal spoonful of Nitratetest N Powder	50 ml	2 ml
Phosphate (P)	Extract P	0.5M Sodium Bicarbonate	5 Extraction P tablets	50 ml	2 ml
Potassium (K)	Extract K	0.1M Magnesium Acetate	One level blue extraction scoop Extraction K Powder	50 ml	2 ml
Calcium (Ca) Magnesium (Mg)	Extract A	1M Potassium Chloride	5 Extraction A tablets	50 ml	10 ml

## Equipment

The equipment required to prepare the soil extracts, and included in Palintest soil test kits, is listed below :-

Palintest Sample Containers, 100/50 ml, plastic	PT 510/PT 506
Soil Scoop, 2 ml	PT 302
Soil Scoop, 10 ml	PT 310
Blue Extraction Scoop	ZP0432
Universal Spoon	ZP0465
Filter Funnel, 7 cm plastic	PT 607
Filter Papers, 11 cm diameter	PT 618

It is important to ensure that the sample containers and filter funnel are clean before the start of each extraction. It is particularly important to wash out all traces of the previous extracting solution as these can seriously contaminate subsequent tests. The sample containers and filter funnel must be thoroughly washed out and then rinsed with deionised water between each extraction. Syringes used to measure extract solutions must be thoroughly cleaned between each test.

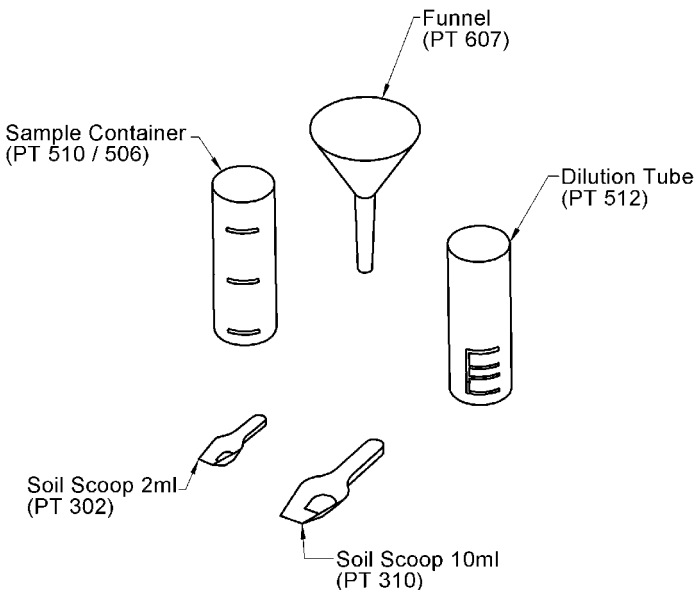

## Filtering and Extract

After the soil has been shaken with the extracting solution for the prescribed period, it must be filtered through filter paper to produce an extract. The filtration is carried out in the following manner.

Take a filter paper circle, fold in half and then fold again into a quarter. Insert a finger between the folds and form the paper into the shape of a cone. Insert the filter paper cone into the filter funnel then place the funnel on the top of a clean sample container.



It is not necessary to collect all of the extract solution. Most of the Palintest procedures have been based on a 10 ml sample of extract so as to minimise the filtration time. Just collect sufficient extract for the tests to be carried out then discard the rest of the soil slurry.

## Diluting Soil Extracts

The composition of different soils varies enormously and test results can extend over a wide range of values. Palintest soil test ranges have been selected to cover the test values most likely to be encountered in garden or agricultural soils. With particular soil types however, or for certain tests, higher values than the test range may be encountered. In these cases it is necessary to dilute the soil extract to bring the solution within the test range.

To simplify dilution procedures, a special Dilution Tube is included in kits. The Dilution Tube enables the extract to be diluted by a factor of 2, 3, 4, 5 or 10 times (see dilution instructions page 24).

It is not possible to dilute the sample when carrying out the Soil pH or Lime Requirement tests.

## Temperature

Temperature affects the rate of soil extraction and the rate of chemical reactions. Palintest soil tests have been calibrated at a temperature of 20°C. Palintest soil extraction procedures and chemical tests should be carried out with the solution as close to 20°C as possible for optimum results.

## Important

The success of the soil tests will depend on following the test instructions carefully and on maintaining clean working conditions throughout the test procedures. Always wash and rinse equipment thoroughly before and after use.

The correct method  
to  
take a level scoop  
of soil

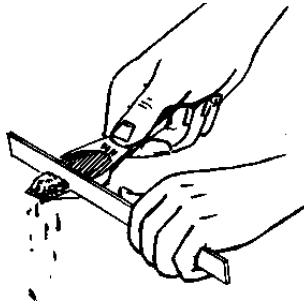
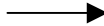

## **TEST INSTRUCTIONS**

### **Soil pH**

Soil pH is a measure of the hydrogen ion activity and is important in determining the availability of plant nutrients. Agricultural soils generally lie within the pH range of 4 - 8.

Neutral soils have a pH value close to 7.0. Soils are considered alkaline if the pH is above 7, and acidic if the pH is below 7. Soils below pH 5 are strongly acidic and will only support acid loving plants.

### **Lime Requirement**

The 'Lime Requirement' of a soil is a measure of the quantity of liming material required to raise the pH of the soil to a specified value. The specified pH value is 6.5 for mineral soil, 6.2 for organic soil and 5.8 for peaty soil. It is not necessary to test soils where the existing pH is higher than these values since in such cases the lime requirement will be zero.

In the Palintest Lime Requirement test, the soil is shaken with a pH buffer and the extent to which the soil modifies the buffer pH is used to determine the lime requirement. The test is carried out as an extension of the Soil pH test. The value given is the amount of calcium carbonate required to raise a 20 cm depth of soil to the pH value specified for the particular soil type.

### **Reagents and Equipment**

Palintest Soil pH Tablets	ST-2200
Palintest Lime Buffer Tablets	ST-2210
Palintest pH Soiltester	PT 320
Soil Scoop, 2 ml	PT 302

## **Test Procedure**

### **Soil pH**

Use the tubes on either side of the Soiltester. Two soil samples may be tested at the same time.

- 1 Take a level 2 ml scoop of soil and place in the Soiltester tube. Fill to the 10 ml mark with deionised water.
- 2 Add one Soil pH tablet then shake the Soiltester gently for one minute.
- 3 Allow the soil to settle then compare the solution against the Soiltester colour standards under daylight conditions. The reading obtained represents the soil pH value.

### **Note**

With certain soils the suspension may be slow to settle and the colours may appear weak. In such cases the test should be repeated using two Soil pH tablets.

### **Lime Requirement**

This test may be carried out as a continuation of the Soil pH test. In this case go directly to step 3 of the instructions below :-

- 1 Take a level 2 ml scoop of soil and place in the Soiltester tube. Fill the tube to the 10 ml mark with deionised water.
- 2 Add one Soil pH tablet and shake the Soiltester gently for one minute.
- 3 Add one Lime Buffer tablet and shake the Soiltester gently for two minutes.
- 4 Allow the soil to settle then compare the solution colour against the Soiltester colour standards under daylight conditions. Note the modified pH reading of the buffer.
- 5 Refer to the Lime Requirement table appropriate to the type of soil under test. The tables show the lime requirement expressed in terms of calcium carbonate ( $\text{CaCO}_3$ ). Quantities are given in various units commonly used in agriculture.

## Mineral Soils

Mineral soils contain less than 10% organic material :-

<b>Soiltester Reading (Modified pH)</b>	<b>Lime Requirement (CaCO<sub>3</sub>)</b>			
	<b>tonne/ha</b>	<b>gram/m<sup>2</sup></b>	<b>cwt/acre</b>	<b>oz/sq yard</b>
4.0	30	3000	240	90
4.5	25	2500	200	75
5.0	20	2000	160	60
5.5	15	1500	120	45
6.0	10	1000	80	30
6.5	4	400	30	12
7.0	0	0	0	0
7.5	0	0	0	0
8.0	0	0	0	0

## Organic Soils

Organic soils contain 10 - 25% organic material :-

<b>Soiltester Reading (Modified pH)</b>	<b>Lime Requirement (CaCO<sub>3</sub>)</b>			
	<b>tonne/ha</b>	<b>gram/m<sup>2</sup></b>	<b>cwt/acre</b>	<b>oz/sq yard</b>
4.0	32	3200	225	95
4.5	26	2600	210	78
5.0	21	2100	165	61
5.5	15	1500	120	45
6.0	10	1000	75	28
6.5	4	400	30	12
7.0	0	0	0	0
7.5	0	0	0	0
8.0	0	0	0	0

## Peaty Soils

Peaty Soils contain greater than 25% organic material :-

Soiltester Reading (Modified pH)	Lime Requirement (CaCO <sub>3</sub> )			
	tonne/ha	gram/m <sup>2</sup>	cwt/acre	oz/sq yard
4.0	34	3400	270	100
4.5	28	2800	225	85
5.0	22	2200	180	65
5.5	17	1700	135	50
6.0	11	1100	85	32
6.5	5	500	40	15
7.0	0	0	0	0
7.5	0	0	0	0
8.0	0	0	0	0

The lime requirement values given in the foregoing tables should be regarded as maximum values. Over-liming should be avoided as this may give rise to trace element deficiencies.

## Liming Materials

The results of the Palintest Lime Requirement test are given in terms of calcium carbonate (ground limestone or chalk). In practice a variety of liming materials are used and regard must be paid to the neutralising value of these materials in order to determine the amounts required from the results given as calcium carbonate.

## **CONDUCTIVITY**

Electrical conductivity provides a means of assessing the level of soluble salts in soil. The test is particularly useful for saline soils, or for glasshouse or other soils which have been subject to prolonged irrigation.

There are various different techniques for measuring soil conductivity. In the method given below the soil is extracted with water at a soil: water ratio of 1:5, and the filtered extract is tested using a Palintest Conductivity Meter. This method provides a quick and simple means of comparing the conductivity or soluble salt content of different soil samples.

### **Equipment**

Palintest Conductivity Meter	PT 159
Sample Container	PT 506/PT 510

Operating instructions for the conductivity meter are given in the Conductivity test instructions.

### **Conductivity Procedure**

- 1 Fill the sample container to the 50 ml mark with deionised water.
- 2 Add one 10 ml scoop of soil, cap tube and shake for two minutes.
- 3 Allow the soil to settle before taking a reading

### **Conductivity Measurement Test Procedure**

- 1 Take the sample container containing the extract and dip in the Conductivity Meter Probe.
- 2 Take the conductivity reading on the meter. The result is displayed in either  $\mu\text{S}$  (microsiemens) or mS (millisiemens).

## **NITRATE (0 – 25 mg/l N)**

Nitrate nitrogen (N) is an important plant nutrient which promotes foliar growth and increased yield.

In the Palintest Nitrate test the soil is extracted using 1M ammonium chloride at a soil:water ratio of 1:25. The extracted nitrate is reduced to nitrite during the extraction stage and then reacted to form a red azo-dye. The intensity of the red colour produced is proportional to the nitrate level in the soil sample.

### **Reagents and Equipment**

Palintest Nitricol N Tablets	ST-2240
Nitratest N Powder	ST-2237
Extraction N Powder	ST-2106
Palintest N / P / Mg Soiltester	PT 322
Soil Scoop, 2 ml	PT 302
Blue Extraction Scoop	ZP0432
Universal Spoon	ZP0465
Sample Container	PT 506/PT 510
Filter Funnel	PT 607
Filter Paper	PT 618

### **Extract N Procedure**

A blue extraction scoop is included in the kit for this procedure, however, it is important that this scoop should NOT be used for measuring soil.

- 1 Fill the sample container to the 50 ml mark with deionised water.
- 2 Add one level blue extraction scoop of Extraction N powder, cap tube and shake to disperse.
- 3 Add one level 2 ml scoop of soil, cap tube and shake for one minute.
- 4 Add one level universal spoonful of Nitratest N Powder, cap tube and shake for one minute.

Filter and collect Extract N in a clean sample container. For optimum results carry out the test as soon as sufficient extract has been collected.

### **Test Procedure**

- 1 Fill the left-hand side of the N/P/Mg Soiltester with Extract N to the 10 ml mark.
- 2 Add one Nitricol N tablet, crush and mix to dissolve.
- 3 Stand for 10 minutes to allow full colour development.
- 4 Compare the solution colour against the Soiltester colour standards. The matching colour represents the nitrate nitrogen level in the soil as mg/l N.

## PHOSPHATE (0 – 100 mg/l P)

Phosphate (P) is a major plant nutrient. It is particularly beneficial in stimulating root growth.

In the Palintest Phosphate test the soil is extracted using 0.5M sodium bicarbonate at a soil:water ratio of 1:25. The extracted phosphate is then reacted with ammonium molybdate under reducing conditions in acidic solution to form a blue coloured complex. The intensity of the blue coloration is proportional to the phosphate level in the soil sample.

### Reagents and Equipment

Palintest Acidifying S Tablets	ST-2276
Palintest Phosphate P Tablets	ST-2260
Palintest Extraction P Tablets	ST-2116
Palintest N / P / Mg Soiltester	PT 322
Soil Scoop, 2 ml	PT 302
Sample Container	PT 506/PT 510
Filter Funnel	PT 607
Filter Paper	PT 618

### Extract P Procedure

- 1 Fill the sample container to the 50 ml mark with deionised water.
- 2 Add five Extraction P tablets, cap tube and shake to disintegrate.
- 3 Add one level 2 ml scoop of soil. Cap tube and shake for one minute. With acid soils some effervescence may be produced - release tube cap periodically to allow any pressure build-up to escape.
- 4 Filter and collect Extract P in a clean sample container.

### Test Procedure

- 1 Add three Acidifying S tablets to 10 ml of Extract P.
- 2 Fill the right-hand tube of the N/P/Mg Soiltester to the 10 ml mark with the Acidified Extract P.
- 3 Add one Phosphate P tablet, crush and mix to dissolve.
- 4 Stand for 10 minutes to allow colour development.
- 5 Compare the solution colour against the colour standards in the N/P/Mg Soiltester. The matching colour represents the phosphate level in the soil as mg/l P.

## **POTASSIUM (0 – 280 mg/l K)**

Potassium, the third of the major nutrients, increases resistance to disease and hardens plant tissue.

In the Palintest Potassium (K) test the soil is extracted using 0.1M magnesium acetate at a soil:water ratio 1:25. The extracted potassium is reacted with sodium tetraphenylboron to form an insoluble white complex which produces a turbidity in the test sample. The degree of turbidity (cloudiness) is proportional to the potassium level in the soil.

### **Reagents and Equipment**

Palintest Potassium K Tablets	ST-2280
Palintest Extraction K Powder	ST-2127
Double Tube Assembly	PT 509
Soil Scoop, 2 ml	PT 302
Sample Container	PT 506/PT 510
Blue Extraction Scoop	ZP0432
Filter Funnel	PT 607
Filter Paper	PT 618

### **Extract K Procedure**

A blue extraction scoop is included in the kit for this procedure, however, it is important that this scoop should NOT be used for measuring soil.

- 1 Fill the sample container to the 50 ml mark with deionised water.
- 2 Add one level blue extraction scoop of Extraction K powder, cap tube and shake to disperse.
- 3 Add one level 2 ml scoop of soil, cap tube and shake for one minute.
- 4 Filter and collect Extract K in a clean sample container.

### **Test Procedure**

- 1 Separate the tubes of the double tube assembly and fill the round outer tube to the top line with Extract K.
- 2 Add one Potassium K tablet, crush and mix to disintegrate.
- 3 Stand for two minutes. A cloudy solution indicates the presence of potassium (over 65 mg/l).

- 4 Insert the square graduated inner tube into the outer tube then, viewing from the top, move the inner tube up and down until the black spot on the bottom is just no longer visible.
- 5 Read the graduation mark on the inner tube level with the top of the solution in the tubes. Refer to the table below which shows the potassium concentration in the soil as mg/l K corresponding to the various tube calibrations.

High levels of ammonia nitrogen may interfere with the potassium test. The test should not be carried out within two weeks following the application of farmyard manure or slurry.

<b>Tube Reading</b>	<b>Potassium mg/l K</b>
No Turbidity	Less than 45
Below 20	80
20	100
30	125
40	150
50	175
60	200
80	260
100	280
Over 100	Over 280

If the test solution is too cloudy (ie the tube reading is over 100), Extract K should be diluted x2 or x4 and the test repeated. Multiply test results by the appropriate factor.

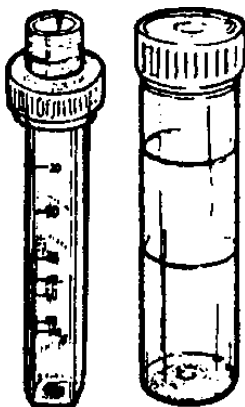

## **MAGNESIUM (0 – 500 mg/l Mg)**

Magnesium is an essential element for the growth of green plants. The ratio of calcium to magnesium is also an important factor in determining the availability of nutrients. If there is an excess of magnesium over the amount of calcium in the soil, plant growth can be seriously affected.

In the Palintest Magnesium test, the soil is extracted using 1M potassium chloride at a soil:water ratio of 1:5. The extracted and exchanged magnesium is then reacted to form an orange complex. The reagent produces a yellow colour in the absence of magnesium. The intensity of the orange colour produced is proportional to the magnesium level in the soil sample.

### **Reagents and Equipment**

Palintest Magnecol S Tablets	ST-2440
Palintest Extraction A Tablets	ST-2136
Palintest N / P / Mg Soiltester	PT 322
Syringe, 1 ml plastic	PT 361
Soil Scoop, 10 ml	PT 310
Sample Container	PT 506/PT 510
Filter Funnel	PT 607
Filter Paper	PT 618

### **Extract A Procedure**

- 1 Fill the sample container to the 50 ml mark with deionised water.
- 2 Add five Extraction A tablets, cap tube and shake to disintegrate.
- 3 Add one level 10 ml scoop of soil, cap tube and shake for two minutes.
- 4 Filter and collect Extract A in a clean sample container.

### **Test Procedure**

- 1 Using the plastic syringe take exactly 1 ml Extract A. Discharge the syringe into either tube of the N/P/Mg Soiltester, then fill the tube to the 10 ml mark with deionised water.
- 2 Add one Magnecol S tablet, crush and mix to dissolve.
- 3 Stand for five minutes to allow full colour development.
- 4 Compare the solution colour against the Soiltester Mg colour standards. The matching colour represents the magnesium concentration in the soil.

## **CALCIUM (0 – 2500 mg/l Ca)**

The amount of exchangeable calcium is an important factor in classifying soil and in making fertilizer recommendations. Calcium stimulates root development and influences the uptake of other nutrients. The ratio of calcium to magnesium is particularly important in determining nutrient availability.

In the Palintest Calcium test the soil is extracted using 1M potassium chloride at a soil:water ratio of 1:5. The exchanged and extracted calcium is then determined by the Palintest tablet count method. Tablets are added to a sample of the extract one at a time until the colour changes from pink to violet.

### **Reagents and Equipment**

Palintest Calcium S Tablets	ST-2297
Palintest Extraction A Tablets	ST-2136
Sample Container	PT 510/PT 506
Soil Scoop, 10 ml	PT 310
Filter Funnel	PT 607
Filter Paper	PT 618

### **Extract A Procedure**

- 1 Fill the sample container to the 50 ml mark with deionised water.
- 2 Add five Extraction A tablets, cap tube and shake to disintegrate.
- 3 Add one level 10 ml scoop of soil, cap tube and shake for two minutes.
- 4 Filter and collect Extract A in a clean sample container.

### **Test Procedure**

- 1 Take 10 ml Extract A in the sample container. Add deionised water to make up to approximately the 50 ml mark. (The amount of deionised water added is not critical - this is merely to increase the working volume of the solution to aid dissolving the tablets and observation of the colour change).
- 2 Add one Calcium S tablet and shake the container until the tablet disintegrates.
- 3 Continue adding tablets one at a time in this manner until the colour of the solution changes from pink to violet.
- 4 Note the number of Calcium S tablets used. Calculate the result of the test using the formula given below. This gives the calcium level in the soil expressed as mg/l Ca :-

$$\text{Calcium (mg/l)} = \text{Number of Tablets} \times 250$$

## **Low Calcium Soils**

For soils with an expected low calcium content, it is preferable to carry out this test on 50 ml of Extract A, made up to approximately 100 ml with deionised water. The result should then be calculated as follows :-

$$\text{Calcium (mg/l)} = \text{Number of Tablets} \times 50$$

## Conductivity Sensor Testing Instructions (PT 159)

**Operating Range:** 0 – 1990 mS/cm, resolution 10  $\mu$ S/cm.

*Before first use:* Soak sensor for two minutes in alcohol to remove oils. Rinse in clean water.

**Calibration:** Remove the cap and unscrew the top battery compartment cover (the interior is shown below) :-

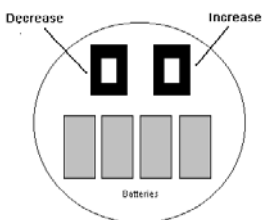

Press the On/Off button to turn the meter on.

Immerse the sensor in a calibration solution (PT 142/7) and allow the reading to stabilise.

Use the increase or decrease buttons to adjust the displayed value to coincide with the standard solution

**Using the Sensor:** Remove cap and press the on/off button on the keypad to turn the meter on. Immerse the sensor in about 20 mm of the test solution. Stir once and let the display stabilise, note the value. Press the hold button if you wish to hold the reading. Press again to release. Press the on/off button to switch the meter off.

To avoid cross contamination between samples, the sensor should be rinsed with deionised water between uses.

**Recalibration:** For optimum performance, recalibrate the sensor regularly. Weekly recalibration is recommended if the sensor is in constant use. Clean the stainless steel electrodes by periodically washing them in alcohol for 10 - 15 minutes. Rinse with water after each use.

**Electrode Replacement:** The electrode itself is replaceable. Please contact Palintest for information on how to replace the electrode.

**Warranty:** This tester is warranted to be free from manufacturing defects for six months.

## **GENERAL INSTRUCTIONS**

### **Care and Maintenance**

Palintest kits are designed to give long service and require very little maintenance. The main requirement is to keep the components in a clean condition. Spillages of test solutions should be wiped up immediately with a damp cloth. In addition to routine cleaning, the sample containers should be washed periodically in warm soapy water.

### **Deionised Water**

Deionised water is required for sample dilution and for the general rinsing of test tubes, etc. The Palintest De-Ion Pack (PT 500) has been specially developed to provide deionised water for use with test kits both in the field and in the laboratory.

The Palintest De-Ion Pack (PT 500) produces approximately five litres of deionised water in 2 - 5 minutes from mains water or from clean natural water sources. Instructions for using the De-Ion Pack are given on the product label and carton.

### **Diluting Samples**

Occasionally, when the test result is outside the concentration range of the test, it may be necessary to dilute the sample and repeat the test. If the result is close to the top of the scale and a more accurate result is required, a dilution may be used to increase the sensitivity of the test :-

- 1 Take a Dilution Tube (PT 512) and fill to the x2 mark with the extract. Make up to the 'Deionised Water' mark with deionised water. Replace the tube cap and mix.
- 2 Carry out the test on the diluted sample as per the normal test instructions.

## Nutrient Level Guide

Parameter	Expression of Results	Maximum Recommended Concentration/Value*
Soil pH	-	7.5
Nitrogen	mg/l	20
Phosphate	mg/l	40
Potassium	mg/l	250
Calcium	mg/l	2000
Magnesium	mg/l	180
Conductivity	$\mu\text{S/cm}$	2000

\* = the maximum limits of each macronutrient will depend upon both the type of crop that is being cultivated and upon the local environmental conditions. Consult [www.palintest.com](http://www.palintest.com) for further details.

The five main elements absorbed from the soil by plants are nitrogen (N), phosphorus (P), potassium (K), calcium (Ca) and magnesium (Mg). They are all classified as macronutrients due to plants adsorbing them on a relatively large scale. Nitrogen, phosphate and potassium are the three that are commonly in sufficiently short supply in soil to inhibit high crop yields.

Nitrogen (adsorbed as ammonium or nitrate ions) is essential for all plant growth as it is a major component of amino acids, the building blocks of proteins. Nitrogen levels need to be sufficiently high as to support plant growth and photosynthesis, whilst excessive levels of nitrogen in the soil may lead to increasing plant vulnerability from insect and fungal organisms.

Plants adsorb phosphorus, as orthophosphate from the soil. Phosphorus plays a fundamental role in the very large number of enzymic reactions within the cells of the plant. Phosphorus deficiency results in the starvation of the plant and can occur with few warning signs in plant condition.

Potassium is the third essential nutrient a plant requires and is used primarily in the synthesis of amino acids. It is also thought to be important the photosynthesis process within plant cells.

Calcium deficiency seems to affect the proper growth of the root tips. It usually occurs in acidic soils and has a detrimental effect on plants by allowing other substances to accumulate in the plant. Excessively high calcium content in the soil can suppress the uptake of magnesium and potassium by the plant roots.

Magnesium is an important constituent of chlorophyll in plants and therefore deficiency (as with calcium, generally occurring in acidic soils) reduces crop yields. Magnesium is also thought to be important in the transport of phosphate throughout the plant.

---